

- 0-150°C Operating Temperature
- Compact Absolute Pressure Sensor
- 1ms Response Time
- Pressure/temperature read-out
- 3.3V Operation
- ± 0.10% Linearity Error
- ± 0.2% Full Scale Error
- 15 Bit Digital Output – SPI
- 6,000/10,000 PSIA Pressure Range
- Media – Harsh Liquid, Air, & Gas

#### DESCRIPTION

The APS100 is a pressure transducer manufactured for a high operating temperature range for the most challenging of applications. This silicon pressure transducer was designed for demanding industrial and commercial applications. The stainless steel media isolated port design allows for pressure measurement of liquid or gas media.

The APS100 series utilizes MEMS piezo-resistive sensors pressurized on the passive backside of the SS diaphragm which has superior long term stability and accuracy (.10% Linearity).

The design is simple and proves value for OEM customers. Please contact the factory for custom design availability.

#### APPLICATIONS

- Mil/Aero
- Industrial Automation
- HVAC
- Automotive Engine
- Compressor
- Pneumatic

### Maximum Environmental Ratings

Operating Temperature ..... 0°C to 150°C  
 Storage Temperature Range .....-55°C to 175°C

Proof pressure ..... 3x full scale pressure  
 Burst pressure ..... 5x full scale pressure

### Package

The one piece body design is made of 316L stainless steel, which allows for easy manufacturability and long term stability.

### Stability

The silicon MEMS pressure sensor is welded into a 316L stainless media isolated housing. That in turn is mounted in the 316 stainless hex housing.

Additional stability is gained from a 2 week factory burn-in.

### Pressure port

The pressure port is F250C Autoclave.

**Ordering:** APS100-6K, APS100-10K

### Cover Marking

Part Number

High temperature Kapton label with the serial number and date code added to the side of the cap.

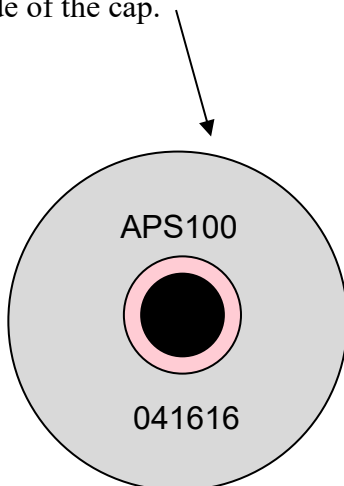

### Media

The 316L media isolated pressure port is tolerant to most media including oil, air, gas, some corrosive media, and salt water.

### Wetted parts

The wetted surfaces are composed of 316L stainless steel.

### Pressure Range

The standard pressure range is 6,000/10,000.

### Soldering

The electrical connection wires for the APS100 sensor can be easily attached to a connector or soldered directly to a board.

## APS100 Digital Output Operational Characteristics

$V_+ = 5V$ ,  $V_- = 0V$ , Temperature = 25°C

PARAMETER	SYMBOL	Min	Typ	Max	UNITS
Supply Voltage	$V_{DD}$	2.7	3.3	5.5	V
Operating Temperature	$T_s$	0		175	°C
Supply Current (Note 1)	$I_{DD}$	70	120	2500	μA
Sleep Mode Supply Current	$I_{stbby}$		.5	32	μA
<b>Accuracy</b>					
Pressure Error		-0.2		0.2	%Full Scan
Non-Linearity (Note 2)		-.1		.1	%Full Scan
Temperature Error (Note 3)		-2		2	°C
Response Time	$t_R$	1	2	20	ms
<b>Analog-to-Digital</b>					
Resolution	ADC		15		Bits
Temperature Resolution			0.1		°C
<b>SPI Interface</b>					
Input Low Level	$V_{in\_low}$	0		.2	Vdd
Input High Level	$V_{in\_high}$	.8		1	Vdd
Output Low Level	$V_{o\_low}$			.1	Vdd
Load Capacitance @SDA	$C_{sda}$ @400khz			200	pF
Pull-Up Resistor	$R_{I2C\_PU}$	500			Ω
Input Capacitance (each pin)	$C_{I2C\_in}$			10	pF

Notes: 1) Measured at zero pressure. 2) Defined as best straight line 3) Measured from 0°C to 150°C.

## Electrical Pin Configuration (Digital [SPI])

Yellow - SCLK  
 Green - MISO  
 White- INT/SS  
 Red - V+  
 Black - GND  
 Orange – MOSI

**Fig. 1**

**Digital Interface – SPI**

- SPI Clock Speed: 125kHz
- Data Order: MSB First
- Clock Polarity: SCK low, idle
- Clock Phase: sample trailing edge
- Chip Select: CS on, idle high

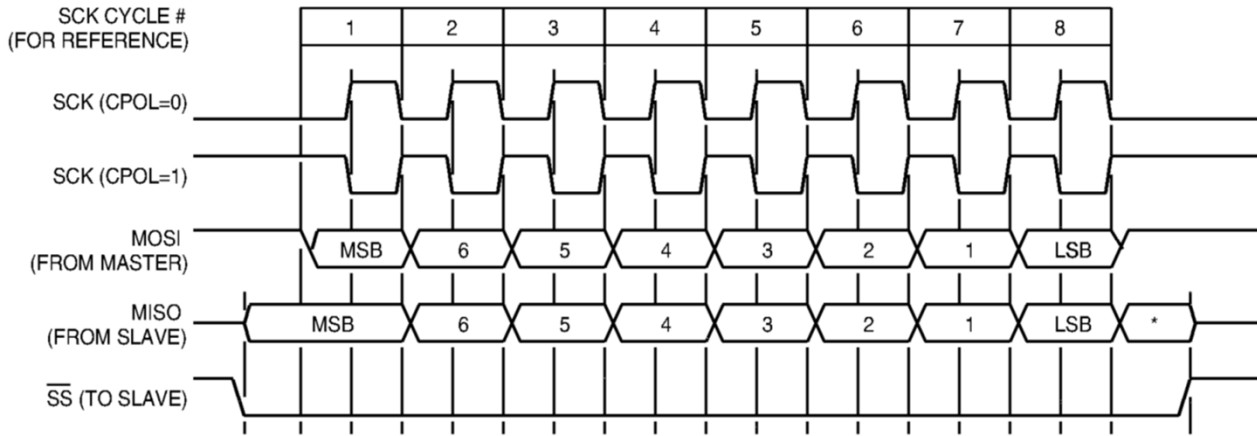

Figure 2

Nr.	Parameter	Symbol	min	typ	max	Unit	Conditions
1	SCK to internal clock frequency ratio	$f_{SCK\_CLK}$			$f_{CLK}/5$		$f_{SCK}$ must be 5 times smaller than $f_{CLK}$
2	MISO hold time after SCK sample slope	$t_{SPI\_HD\_MISO}$	200			ns	
3	MOSI setup time before SCK sample slope	$t_{SPI\_SU\_MISO}$	$2/f_{CLK}$				
4	/SS setup time before SCK sample slope	$t_{SPI\_SU\_SS}$	10			ns	
5	/SS hold time after SCK sample clk	$t_{SPI\_HD\_SS}$	$1/f_{SCK\_CLK}^*$				

Figure 3

# Sensor Outputs

## Digital Interface - SPI

**Read Command**  
Send 0x02

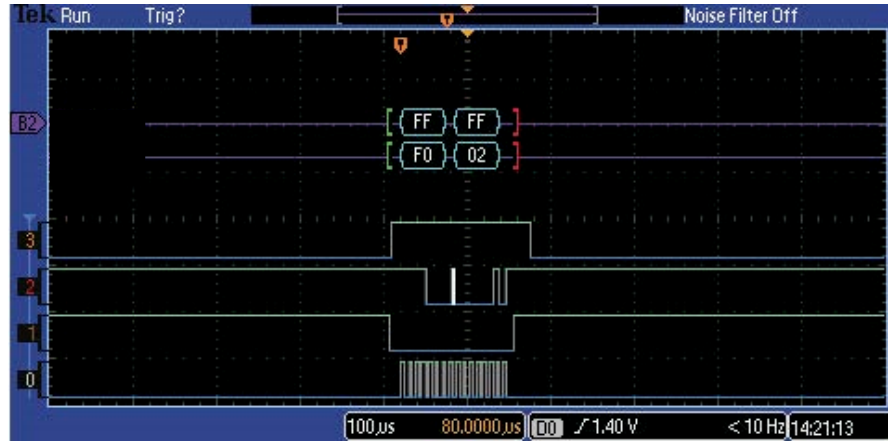

**Data Output**  
CS/ (1) Pulled Low  
Starts Data Output

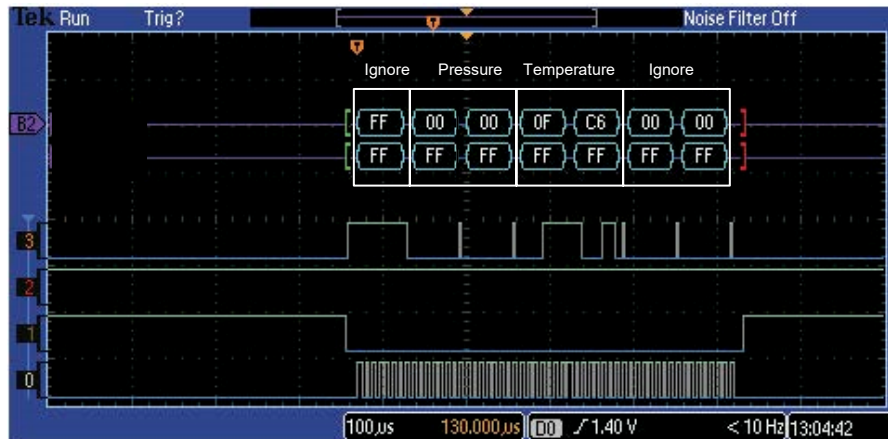

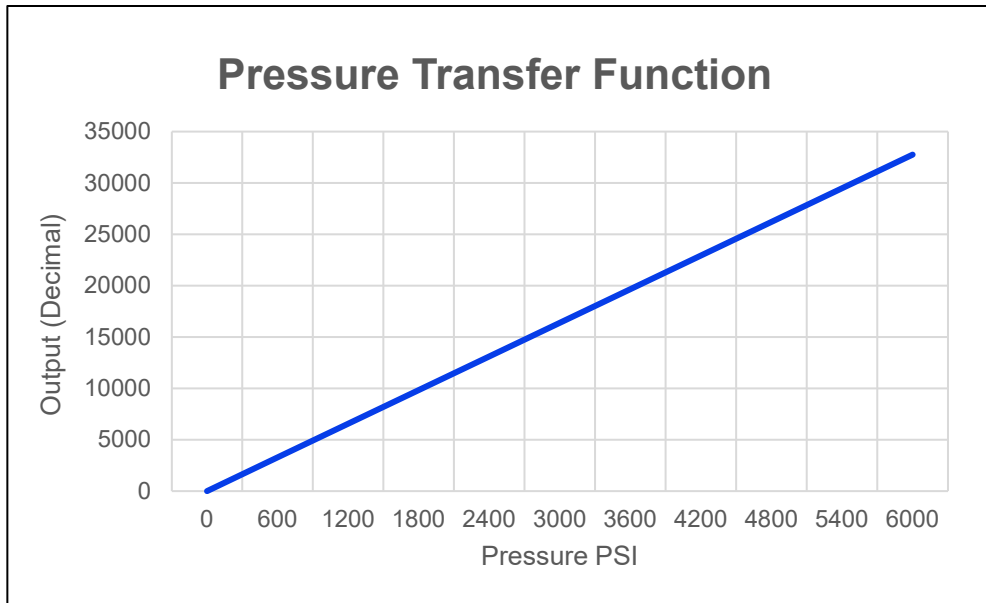

PSI		% Output	Decimal	Hex
0	0	0	0	0 x0000
600	1000	10	3277	CCC
1200	2000	20	6554	1999
1800	3000	30	9830	2666
2400	4000	40	13107	3333
3000	5000	50	16384	4000
3600	6000	60	19661	4CCC
4200	7000	70	22938	5999
4800	8000	80	26214	6666
5400	9000	90	29491	7333
6000	10000	100	32768	8000

## Sensor Outputs

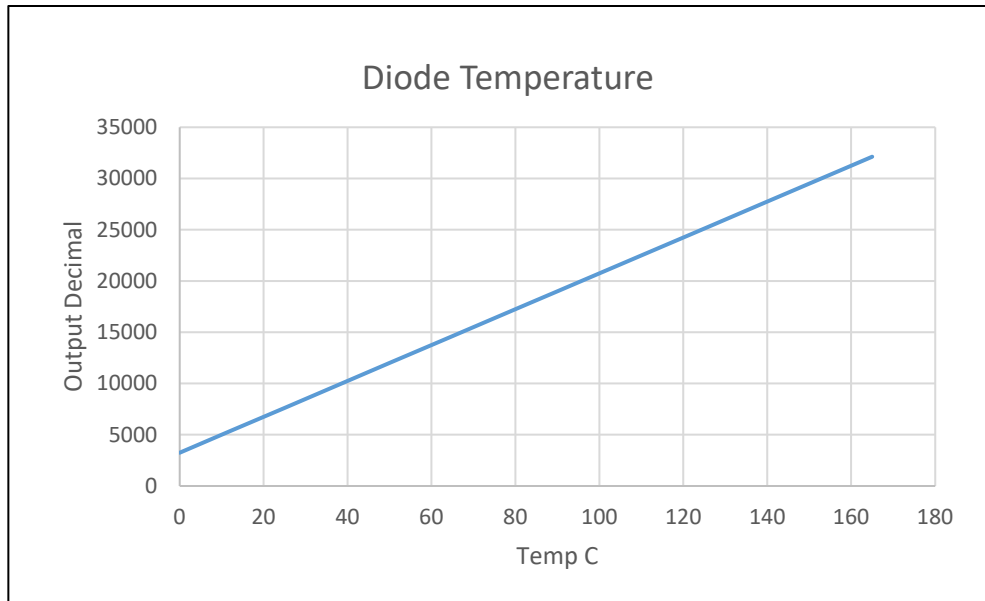

Temp C	Decimal	Hex
0	3250	CB2
25	7625	1DC9
50	12000	2EE0
75	16375	3FF7
90	19000	4A38
100	20750	510E
125	25125	6225
150	29500	733C
165	32125	7D7D

# Mechanical Dimensions (inches)

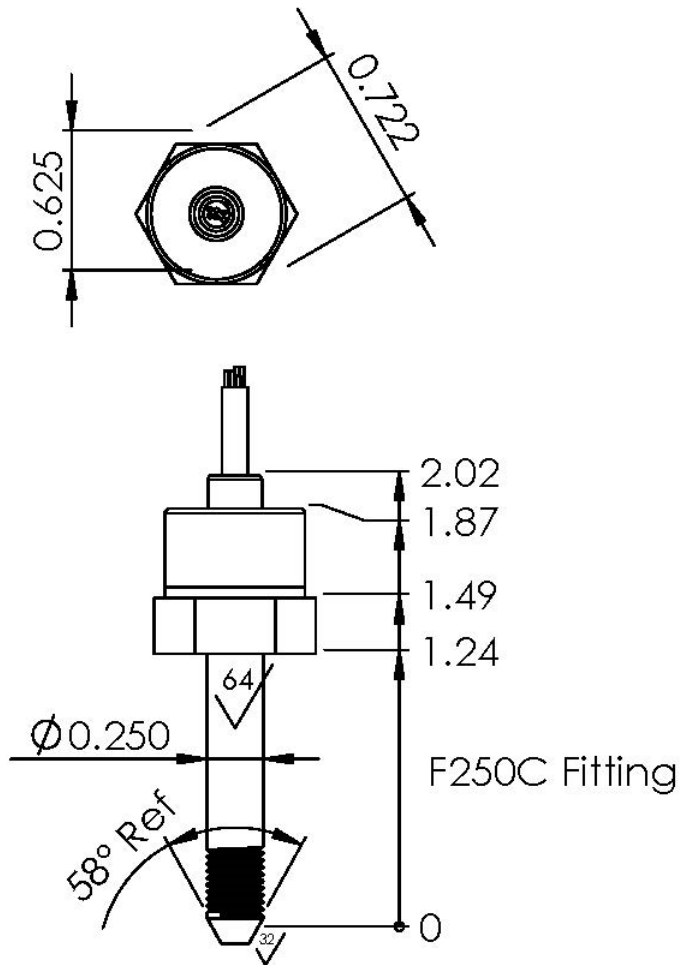

Ph: (520) 858-0251 Fax: (520) 468-2475 [sales@azsenco.com](mailto:sales@azsenco.com)

## Notice:

AzSensCo LLC reserves the right to make changes to the product contained in this publication. AzSensCo LLC assumes no responsibility for the use of any circuits described herein, conveys no license under any patent or other right, and makes no representation that the circuits are free of patent infringement. While the information in this publication has been checked, no responsibility, however, is assumed for inaccuracies.

AzSensCo LLC does not recommend the use of any of its products in life support applications where the failure or malfunction of the product can reasonably be expected to cause failure of a life-support system or to significantly affect its safety or effectiveness. Products are not authorized for use in such applications.